

Load Frequency Control of Hybrid Power System Using IGWO Technique

^{1st} Kammili Sirisha, ^{2nd} M.Jayalakshmi Devi

¹Lecturer, ²Lecturer

^{1,2} Department of Physics,

^{1,2} SIR C R Reddy College for Women, Eluru, Andhra Pradesh, INDIA

Abstract – The main aim of the paper is to design a load frequency controller for an Isolated Hybrid Power system. The isolated hybrid power system presented in this paper uses renewable sources for power generation and a storage system feeding load to a remote island. The studied system comprises of wind-turbine generators (WTGs) and waveenergy turbine generators (WETGs) for power production and a compressed air energy storage (CAES) system for storage. It can be verified from the simulation results that the isolated-hybrid system feeding load can stably operated to attain power and frequency stability by using Proportional Integral (PI) Controller. The Gains of the controller are obtained from a novel optimization technique named as Improved Grey Wolf Optimization (IGWO).

IndexTerms - Improved Grey Wolf Optimization (IGWO), Load frequency controller, Hybrid power system, Wave energy, Wind turbine generator.

I. INTRODUCTION

Wind and wave (tidal waves) are intermittent energy sources and do not usually meet load demands at all times. Conventional generation of electricity from fossil fuels causes environmental pollution. Therefore to improve power supply to demand, power is harvested from the distributed generation resources. Unpredictability of these two energy sources in standalone system reflect in output active power and frequency thus are unreliable to meet load requirements [1]. Thus, in developmental stage of such hybrid system, the instability of the system output is compensated by adding a suitable energy storage system. Hence, a compressed air energy storage system (CAES) is introduced into the hybrid wind and wave power generation system. The added energy storage will store energy during low load demand period and helps to stabilize the system on increased demand [2]. The advantage of this storage system is that it also eliminates threat of battery disposal, the conventional storage system.

Here, the active power balance is improved by introducing a proportional-integral (PI) controller. The controllers are optimized for improved settling time and reduced overshoot in frequency deviation resulting due to active power unbalance. The optimization is carried out by recently proposed efficient Improved Grey Wolf Optimizer (IGWO) [3].

II. SYSTEM MODELLING

The generation system comprises two wind turbine generator (WTG) along with, one wave energy turbine generator (WETG) and the CAES for storage purpose shown in MATLAB Simulink model in Fig. 1. The load is connected to the CAES subsystem. During the off peak load the CAES stores the surplus energy and when the load peaks up, the CAES supplements energy to meet the load requirement [4-5]. The net power generation P_s is the sum of output power obtained from the WTGs P_{WTG} , from WETGs P_{WETG} and the exchanged power of the CAES P_{CAES} .

The expression of P_s is expressed by

$$P_s = P_{WTG} + P_{WETG} \pm P_{CAES}$$

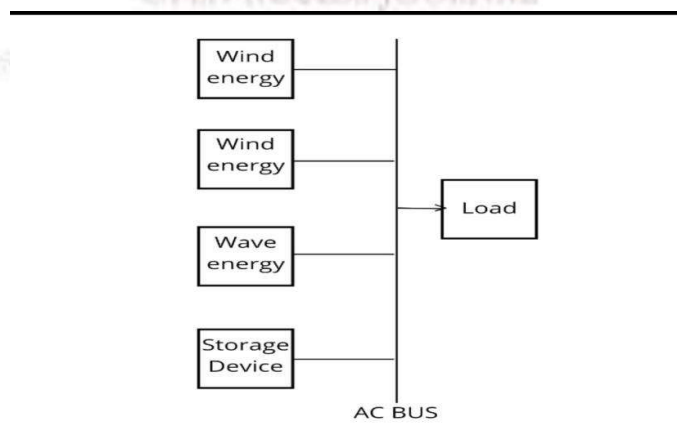

Fig 1: Single line diagram of Proposed System

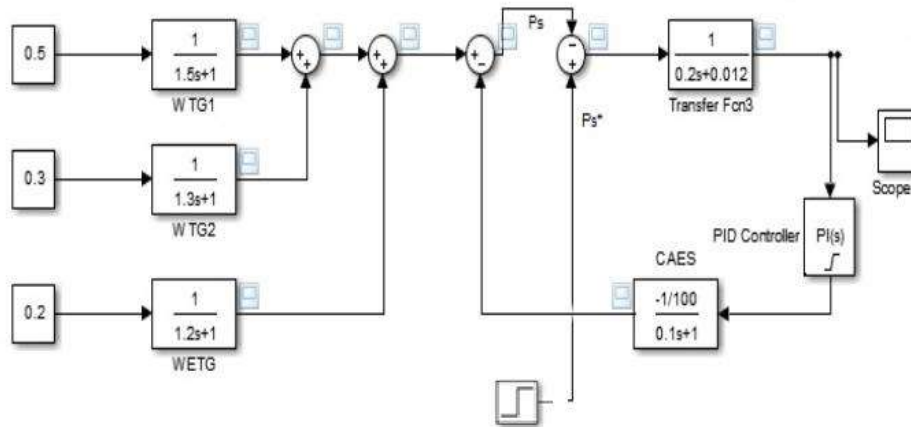

Fig 2: Simulation Block diagram of Proposed System

2.1. Wind Power Generation

Power content in offshore wind is more than on land and small wind farms can feed electricity to isolated off-grid locations. Here wind is used to generate electricity. Wind power is a renewable source of energy and does not create any atmospheric pollution and also it is cost effective and uses little land [6]. Neglecting non-linearities the model of WTGs is reduced to a transfer function

$$G_{WTG}(s) = \frac{K_{WTG}}{1+sT_{WTG}} = \frac{\Delta P_{WTG}}{\Delta P_w}$$

With K_{WTG} , the gain and T_{WTG} the time constant of WTG respectively for small change of output power ΔP_{WTG} for corresponding change in input ΔP_w .

2.2. Tidal Wave Energy Power Generation

Tidal power, also called tidal energy, is a form of hydropower that converts the energy obtained from tides into useful form of power, mainly electricity. It can be harnessed where high a tidal flow velocity is present [7]. The transfer function of WETG is represented in a simple form

$$G_{WETG}(s) = \frac{K_{WETG}}{1+sT_{WETG}} = \frac{\Delta P_{WETG}}{\Delta P_a}$$

With K_{WETG} the gain and T_{WETG} the time constant of WETG respectively for small change of output power ΔP_{WETG} for corresponding change in input ΔP_a from wave.

2.3. Compressed Air Energy Storage System (CAES)

In compressed air energy storage (CAES) system the energy generated during one time is used when needed using compressed air. The energy generated during the low load hour can be released to meet peak load demand [8]. The storage system is represented in model as

$$G_{CAES}(s) = \frac{K_{CAES}}{1+sT_{CAES}} = \frac{\Delta P_{CAES}}{\Delta f}$$

With K_{CAES} – the gain and T_{CAES} - time constant respectively for small change of output of CAES ΔP_{CAES} corresponding to Δf frequency deviation.

2.4. Power-Frequency deviations

As the hybrid system used is highly fluctuating in nature it requires special control strategies. So, we use a PI controller to alleviate mismatch between generation and demand [9]. The power control strategy is obtained by using the difference of power demand P_L and net power generation P_S .

$$\Delta P_e = P_S - P_L$$

Practically there will be a delay in the frequency characteristics and hence, in the above equation modification is required by controlling inherent time delay between system frequency variation and power deviation [10]. The transfer function for system frequency variation to per unit power deviation can be expressed by

$$G_{SYS}(s) = \frac{\Delta f}{\Delta P_e} = \frac{1}{K_{SYS}(1+sT_{CAES})} = \frac{1}{D + Ms}$$

Where, M and D are the equivalent inertia constant and damping constant of the hybrid system considered respectively.

2.4. Objective Function

IGWO is used to minimize the standard objective function Integral of Square Error (ISE) of frequency deviation which is the fitness evaluation of wolves. The integral square error is denoted by J. The mathematical value of J is:

$$J = \int^T \min (\Delta f)^2$$

III. IMPROVED GREY WOLF OPTIMIZER (IGWO)

An Improved Grey Wolf Optimizer (I-GWO) is proposed for solving global optimization and engineering design problems. This improvement is proposed to alleviate the lack of population diversity, the imbalance between the exploitation and exploration, and premature convergence of the GWO algorithm. The I-GWO algorithm benefits from a new movement strategy named dimension learning-based hunting (DLH) search strategy inherited from the individual hunting behaviour of wolves in nature. DLH uses a different approach to construct a neighbourhood for each wolf in which the neighbouring information can be shared between wolves. This dimension learning used in the DLH search strategy can enhance the balance between local and global search and maintains diversity. The performance of the proposed I-GWO algorithm is evaluated on the CEC 2018 benchmark suite and four engineering problems. In all experiments, I-GWO is compared with six other state-of-the-art metaheuristics. The results are also analyzed by Friedman and MAE statistical tests. The experimental results and statistical tests demonstrate that the I-GWO algorithm is very competitive and often superior compared to the algorithms used in the experiments. The results of the proposed algorithm on the engineering design problems demonstrate its efficiency and applicability.

In GWO, α , β , and δ lead ω wolves toward the areas of the search space that are promising for finding the optimal solution. This behaviour may lead to entrapment in locally optimal solution.

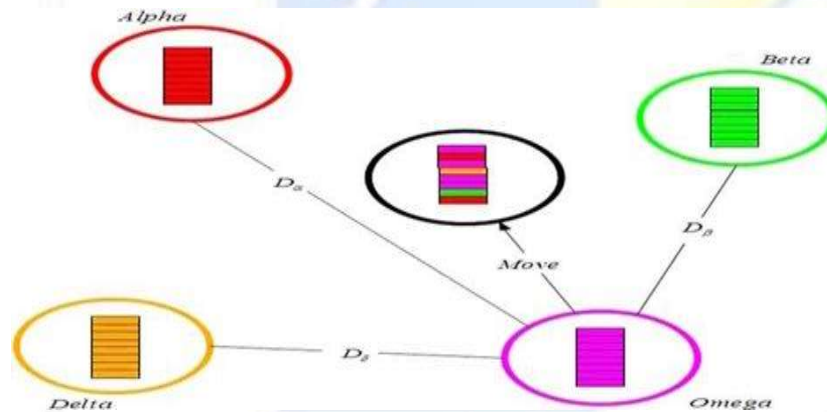

Fig 3: Parameter positions of IGWO

Another side-effect is the reduction of the diversity of the population and cause GWO to fall into the local optimum. To overcome these issues, in this section, an improved grey wolf optimizer (I-GWO) is proposed. The improvements include a new search strategy associated by selecting and updating step, which are indicated in the dashed line border in the flowchart of I-GWO shown in below figure.

The mathematical representation of proposed improved grey Wolf optimizer follows:

$$\left\{ X_i(t + 1) = \begin{cases} X_{i-GWO}(t + 1), & \text{if } f(X_{i-GWO}) < f(X_{i-DLH}) \\ X_{i-DLH}(t + 1), & \text{otherwise} \end{cases} \right\}$$

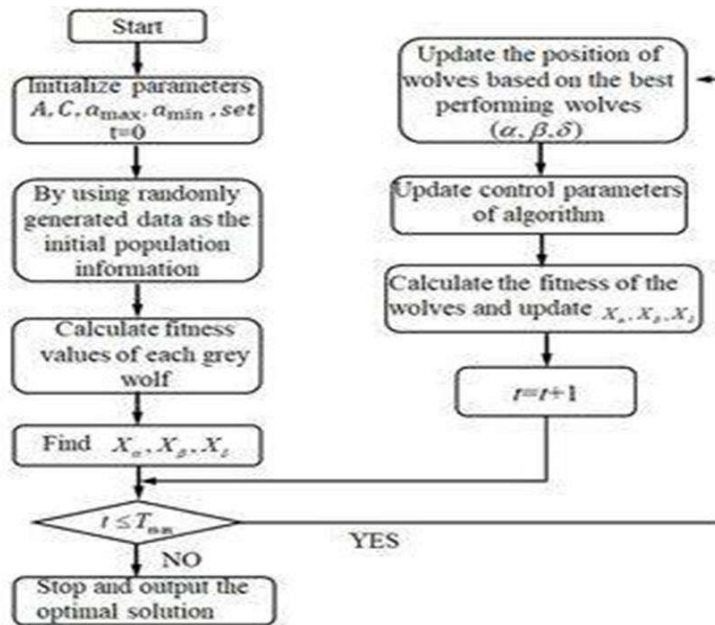

Fig 4: Flowchart of IGWO technique

IV. RESULTS AND DISCUSSIONS

Simulation block diagram of hybrid power system modelling mainly consists of two wind energy power generating systems, one tidal wave energy power generating system and compressed air energy storage system (CAES) which are connected to the load. In this work two different input loads variations are given to the system they are:

Case (i): Step load perturbation :(1%SLP)

The step load perturbation means that total load given to the hybrid system is 1% of per unit load.

Case (ii): Random Load perturbation:

In this case the total load given to the hybrid system simply taken a random input load value.

4.1 Case (i): Step load perturbation :(1%SLP)

From the above simulation block diagram it consist of two number wind energy stations, one tidal wave energy station and cases energy system. The transfer function of each block we are taking only first older values it means to minimize the complexity of the system because the hybrid power system consist a very small of loads compared to main power stations. The power generated from WETG and WTGS are 0.2 pu and 0.8 pu respectively. Total power from generators is 1 pu. The comparative frequency deviations of the system for the step load perurbation for IGWO are given below.

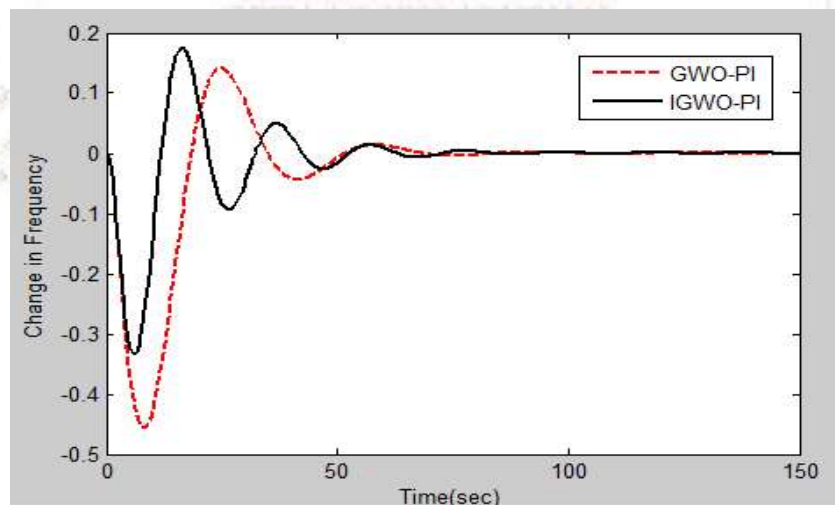

Fig 5: Comparative Frequency Deviations of controllers under case-1

4.2 Case (ii): Random Load perturbation

In this case the step load perturbations are been replaced with random load for a certain period. This random load is displayed in the figure below.

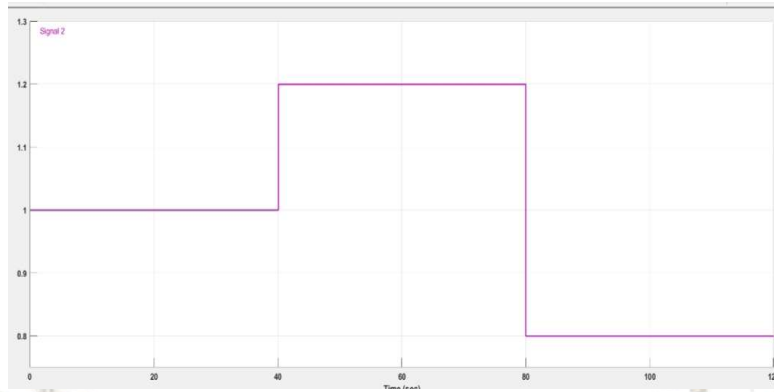

Fig 6: Random Load Perturbation

The comparative frequency deviations of the system for the Random load perurbation for IGWO are given below.

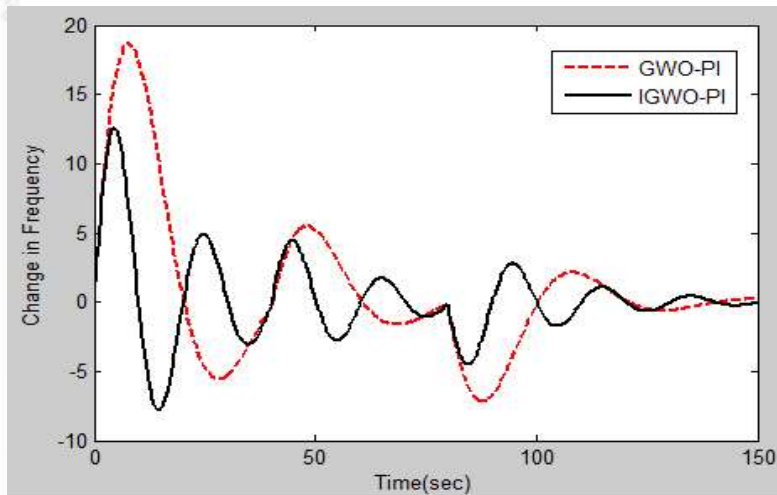

Fig 7: Comparative Frequency Deviations of controllers under case-2

V. CONCLUSION

This paper presents the frequency analysis for the controller design of an isolated hybrid power system for power supply to a remote island. The system contains two wind turbine generators and one wave energy turbine generator and a compressed air energy storage system. The transfer function of WTGs, WETG and CAES are represented by first order system. It can be concluded from the frequency results of IGWO tuned PI controlled system can be effectively meet the step load and random load variation in power demand. The system frequency deviation is properly controlled with in a small range. Better controller can be developed on this system using other approaches and compared for improvement.

Appendix A. Parameter values of studied Hybrid System

$K_{WTG1} = 1.0$, $T_{WTG1} = 1.5\text{sec}$, $K_{WTG2} = 1.0$, $T_{WTG2} = 1.3\text{sec}$, $K_{WETG} = 1.0$, $T_{WETG} = 1.2\text{sec}$, $K_{CAES} = -1/100$, $T_{CAES} = 0.1\text{sec}$, $M = 0.2$ and $D = 0.012$.

VI. REFERENCES

- [1] P. Kundur, Power System Stability and Control. 1994. New York: McGraw-Hill.
- [2] A. J. Wood and B. F. Wollenberg. 1966. Power Generation Operation and Control, 2nd ed., John Wiley & Sons. New York. pp. 328-362.
- [3] Mirjalili S, Mirjalili S M, Lewis A. Grey Wolf Optimizer, Advances in Engg Software 2014; 69: 46-61.
- [4] K.R. Sudha, R. VijayaSanthi. 2012. Load Frequency Control of an Interconnected Reheat Thermal system using Type-2 fuzzy system including SMES units. Electrical Power and Energy Systems, Vol. 43, pp. 1383–1392.
- [5] V. Donde, M. A. Pai, and I. A. Hiskens. 2001. Simulation and Optimization in an AGC System after Deregulation. IEEE Transactions on Power Systems, Vol. 16, pp. 481–489.
- [6] T. C. Yang, Z. T. Ding, and H. Yu. 2002. Decentralized Power System load frequency control beyond the limit of diagonal dominance. Electrical Power and Energy Systems, Vol. 24, pp. 173-184.
- [7] Pavan Kumar Neeli, V. S. R., and U. Salma. "Automatic Generation Control for Autonomous Hybrid Power System Using Single and Multi-objective Salp Swarm Algorithm." International Conference on Intelligent Computing, Information and Control Systems. Springer, Cham, 2019.
- [8] Neeli, VSR Pavan Kumar, et al. "Design of Load frequency controller using Whale Optimization Algorithm (WOA)." 2022 IEEE 2nd Mysore Sub Section International Conference (MysuruCon). IEEE, 2022.
- [9] Neeli, VSR Pavan Kumar, and Nerella Sameera. "JAYA Algorithm Based Frequency Regulation of Thermal Power System Interconnected With Micro Grid." Solid State Technology 63.6 (2020):pp: 12535-12542.
- [10] K.R. Sudha and R. VijayaSanthi. Robust decentralized load frequency control of interconnected power system with Generation Rate Constraint using Type-2 fuzzy approach. Electrical Power and Energy Systems, Vol. 33, pp. 699-707.

